



OCTOBER 2017



*Abe McCullough – our 100th member*

### Our 100th Member for 2017

#### In This Issue

<i>President's Corner ... ..2 &amp; 3</i>	<i>October Meeting Photos... ..8</i>
<i>Elbert Dale Demo..... 4</i>	<i>October Meeting Minutes... ..9</i>
<i>October Skills Center... ..5</i>	<i>Safety Paddle Switch Article...10</i>
<i>Cheese Shop Inv. and needs...6</i>	<i>Calendar for balance of 2017 ....11</i>
<i>Club Challenge Winners ... ..7</i>	



### President's Corner

October 2017

CVW Meeting

President's Corner – Bob Welch

Many thanks to members who help setup and stay to put things away after meetings. Thanks also to mentors help at skills training and members who work behind the scenes to make our club a success.

October's meeting featured skew expert Elbert Dale whose demo is summarized in the following minutes taken by Jay Lindhjem filling in for Ron Capps. Great job of taking detailed notes, Jay.



Jerry Jorgensen reported our finance in Richard Landreth's absence. We are in a healthy financial position, but will continue to wisely manage this resource.

Per our constitution and bylaws, we presented candidates for the next term in October for membership vote at our next meeting in November. We will then advise AAW of the results.

**The executive group must be AAW members:**

President	Bob Welch	
VP Programs	Mike Sorge	(currently Fred Williamson)
VP Membership	Phil Evans	(currently Don Voas)
Secretary	Jay Lindhjem	(currently Ron Capps)
Treasurer	Jerry Jorgensen	(currently Richard Landreth)

**Also the following management team members:**

Newsletter Editor	Bill Hemminger	
Web Master	Tim Quillen	
Librarian	Judy Stock	(currently Mars Champaign)
Audio/Visual Coordinator	<b>Open</b>	(currently John O'Neil)
Club Store Manager	Kirk McCauley	
Food Services Coordinator	Buck Culver assisted by Paul Tolar	
Denny Martin Woodturning Skills Center Coordinator	Jim Oates	
Ruritan Liaison	Dan Stogdale	(currently Tom Evans)
Virginia Symposium Representative also Board Chairman)	Bob Welch Bob Welch, Richard Landreth (who is	

(Continued on page 3)

The Wood Spinner is published monthly by the Central Virginia Woodturners.

[www.centralvawoodturners.org](http://www.centralvawoodturners.org); Bob Welch: President [rvjwelch77@gmail.com](mailto:rvjwelch77@gmail.com)

Bill Hemminger: Editor [bhemminger@bankdesign.net](mailto:bhemminger@bankdesign.net), Telephone (540) 649-6990



Presidents Corner continued from Page 2

John O'Neil is stepping down after twelve years as our Audio/Visual Coordinator and he received a huge applause by attendees for his outstanding service. The new A/V equipment is much simpler to set up. We need a few members to step up to do this. Please contact me or any of the above executive group if you have an interest.

The 2018 Virginia Symposium held at the Expoland Center asked us to recommend candidates to potentially be selected as demonstrators. Compensation will be negotiated by the Symposium on a one-on-one basis. So far we have two candidate interested: Elbert Dale and Fred Williamson. If you are also, please let me or Richard Landreth know. We will also welcome CVW applicants for Videographers for the 2018 Symposium with compensation offsetting cost of admission, plus giving Videographers a close up look at the demo and opportunities to meet the great slate of demonstrators.

Mike Sorge, Proposed Programs VP, held a preliminary team member meeting and is developing a great set of programs for 2018. Keep tuned for updates on this.

Don Voas, Membership VP, introduced a new club member and our guests. With new members joining in October, we have over one hundred members. Don reminded members to submit pieces for sale at the cheese shop, where revenues go to our club treasury.

For our safety minute, Jim Oates showed one of the safety shutdown switches he made for our club based on the one Alex Pettigrew showed us last month. Jim will publish components, cost and sourcing for club members to inexpensively make this for their lathes.

Jim said attendance at the Skills Center continues to be high and is a source of new members. He thanked mentors who regularly come to help teach wood turning.

'Show and Tell' as usual was full of fabulous creations by members. The '2x4' Contest items were also shown at the table and winners listed in the meeting minutes were selected for new and experienced wood turners. Thanks to Don Voas for starting this contest.

Best regards,

Bob

[Rvjwelch77@gmail.com](mailto:Rvjwelch77@gmail.com)/540-248-6801

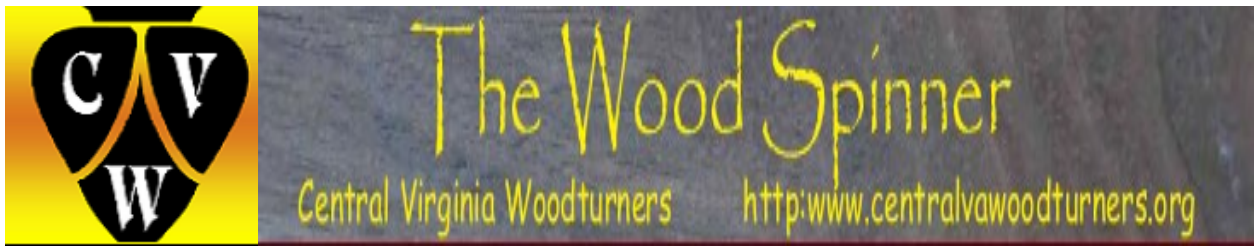

## Demonstration by Elbert Dale on the Skew



Once again, during this demonstration we were shown that size doesn't matter. Dale used a huge skew to make miniature tops.

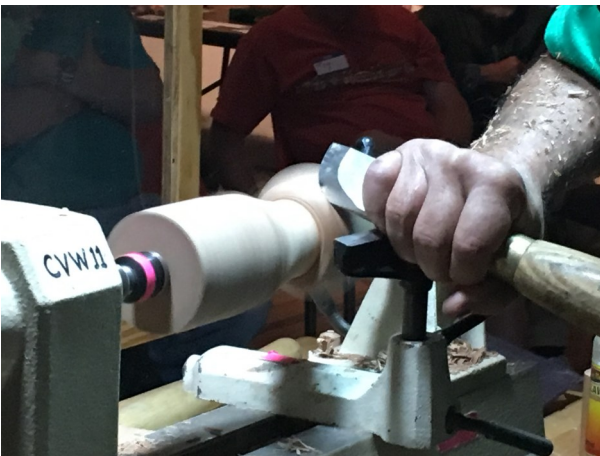

Dale was also our second place winner of the 2X4 Challenge in the over two year experience category



# The Wood Spinner

Central Virginia Woodturners <http://www.centralvawoodturners.org>

## Scenes From the October Skill Center Session



Four new Students  
Know safety, no injury. No  
safety, know injury.



Future 100th member



First you cut the blank



Then you sharpen the tools



Then you stop  
for donuts



And Coffee



A bad day woodworking is better than a good day working. ~Author unknown



Remember the  
blank?  
We had a visitor  
from England – An  
Experienced  
turner – Arnie  
Wright. He has  
great skills and an  
eye for beautiful  
wood. Come back  
anytime





## CHEESE SHOP INVENTORY – NEEDS FRESH TURNINGS

The peak gift-giving season of the year is near, and the only items available to add to the Central Virginia Woodturners inventory for sale at the Cheese Shop are three bowls donated by Dennis Hippen, two ice cream scoops contributed by Don Lum and an unique winged turning by Tom Evans. Help!

About four years ago, CVW President Tom Evans and the executive officers wanted to provide a skills development center so our members could expand their woodturning capabilities and potential members could learn safe basic woodturning techniques. The “president’s challenge” was established to raise funds to undertake this objective.

Membership Vice President Jimmy Guynn at the time offered to accept the responsibility, in addition to his other duties, to identify one or more vendors willing to market CVW wood turnings, collect donated items from CVW members, and act as the CVW agent with the vendors. Jimmy contacted a number of retailers. The Cheese Shop was the only one interested in working with us.

The Cheese Shop is an Amish style store located at 2366 Tinkling Spring Road (Rt. 608), about a mile north of Stuarts Draft. It specializes in selling a wide variety of cheeses, baking ingredients, candies, bulk foods, deli meats, snacks, etc.

CVW wood turnings are the only craft items offered. We receive 70% of the sales price for our donated items. Our 2017 budget includes \$250 projected income with \$194 received by the end of September (includes some items sold in late 2016). About \$500 was received from donated turnings last year. Individual item pricing is set by a random panel of five to ten CVW members. Their suggested retail prices for each item are averaged and roughly rounded for the invoice submitted to the Cheese Shop which is allowed to offer up to 20% discount for special sales events.

The Cheese Shop does not want to sell pens, candlesticks, segmented turnings, weed pot/bud vases, bottle stoppers or anything that looks like or indicates social spirits. Bowls, platters and similar items seem to sell well. The vast majority of items sell for less than \$50; many for much less.

CVW members are encouraged to contribute their best turnings to this fund-raising effort which enables even better demonstrations, training and growth of our club. So, please go through your vast accumulation of wood turnings -- those that you admire with pride -- and consider donating some of them to the growth of Central Virginia Woodturners. Only fully finished (not just rough turned) pieces should be submitted to Membership Vice President Don Voas for pricing and communication with the Cheese Shop. You are encouraged to visit the Cheese Shop, but do not take your turned wood items directly to them.



## Central Virginia Woodturners Club Challenge Oct. 17, 2017

All Central Virginia Woodturners members were challenged to create “something” using all or part of one construction grade 2”x4”x8’ wood stud (pine, spruce, fir, etc.).

Two Years turning or less Winners

First Place John Hinton, Second Place Donnie Maupin, Third Place Paul Tolar



Two Years turning and over Winners

First Place - Don Voas, Second Place - Elbert Dale, Third Place – Jim Adamac





# The Wood Spinner

Central Virginia Woodturners <http://www.centralvawoodturners.org>

## Photos from the October Meeting



Law of the Workshop: Any tool, when dropped, will roll to the least accessible corner.

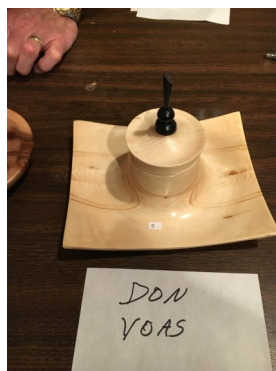
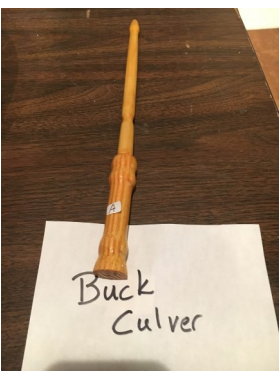





# The Wood Spinner

Central Virginia Woodturners <http://www.centralvawoodturners.org>

CENTRAL VIRGINIA WOODTURNERS

MEETING MINUTES

October 17, 2017, 2017

The General Meeting:

The October meeting, attended by 59, was called to order at 7 PM by president Bob Welch. Bob thanked all volunteers, including those helping with meeting setup, for their support.

The Virginia symposium will be held November 2018. We may nominate demonstrators from our club prior to October 22. There are 3 slots open at this time.

Election of officers for the next two years will be held at the November meeting. The slate of candidates for the executive group is as follows.

President	Bob Welch
VP Programs	Mike Sorge
VP Membership	Phil Evans
Secretary	Jay Lindhjem
Treasurer	Jerry Jorgensen

The management team will be as follows:

Newsletter editor	Bill Hemminger
Webmaster	Tim Quillen
Librarian	Judy Stock
A/V Coordinator	OPEN
Store Manager	Kirk McCauley
Food Services	Buck Culver & Paul Tolvar
Skills Center	Jim Oates
Ruritan Liaison	Dan Stogdale
Symposium Rep.	Bob Welch & Richard Landreth

Bob stressed that we need an A/v coordinator. John O'Neil has held this position for 12 years.

Don Voas introduced new member Jeff Beebe and guests Alexandria (Alex) Machita, Abraham (Abe) McCullough, Norman (Norm) Dallura and Arnie Wright from England. Alex, Abe and Norm joined CVW at the conclusion of the meeting bringing our membership to 101 members. Don also outlined voting instructions for the "2x4" turning challenge.

Jerry Jorgensen, filling in for Richard Landreth, gave the treasurer's report.

During the safety minute, Jim Oates described the need for a remote shut off switch to avoid having to reach into the "red zone" should a work piece become unstable. He also outlined the switch construction.

Discussing the progress of the Denny Martin Skills Center, Jim Oates noted that 2 1/2 years ago, prior to opening the center, CVW had 44 members, and we are now approaching 100.



CENTRAL VIRGINIA WOODTURNERS, MEETING MINUTES, October 17, 2017, 2017

The General Meeting: October Meeting minutes continued.

Fred Williamson conducted the show & tell portion of the meeting which was led off by the "2x4" challenge. The winners by popular vote were:

Novice: 1st - John Hinton's dyed hollow form, 2nd - Donnie Maupin's bowl, 3rd - Paul Tolar's segmented bowl

Experienced: 1st - Don Voas' box on a curved base, 2nd - Elbert Dale's mount for shells from a military funeral, 3rd - Jim Adamek's finial

Elbert Dale presented a demonstration using the skew chisel. He focused on finger tops including one as small as a finger tip.

The meeting was concluded at 9:00

## Safety Paddle Switch

### Material list for remote shut off that can be moved from lathe to lathe:

Direct from Powertech on Amazon

Paddle switch - Powertech 71007 110/220v -\$12.99

Available at Lowes or Home depot:

Extension cord 12 gauge minimum length to suit. Either 110 or 220 v plug and socket as required. Or 12 Ga flex cord and appropriate male and female connectors

4 - Closed terminals to connect to switch. 12 gauge capacity.

1 plug connector for ground wire. 12 gauge capacity., 1 - Outdoor electrical box - extra depth  
2 - NM Cable Connector 1/2" knockout, 3/8" trade size, Glue or double stick tape.

Salvage:

Speakers contain powerful magnets that can support the switch and are available to most but can be obtained reasonable from a local thrift store. Remove from enclosure and separate from speaker cone. Grind rivets flat. Attach to rear of box check hold strength and mount weak side to box. An alternate is to mount the box permanently near the tail stock of the lathe



Alex Pettigrew.

If wiring 220v connect both white and black leads across switch and check rotation after assembly. If lathe runs backward, reverse leads plug. If wiring 110v connect black wire to switch and join the white wires and connect ground to box.

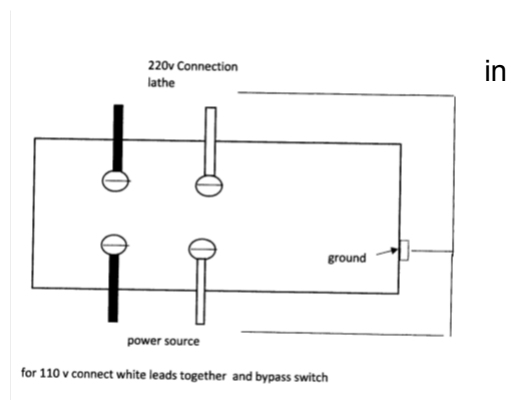

Original design from



### Proposed CVW 2017 Programs Schedule

November 11	9:00AM to Noon	Woodturning Skills Center
November 21	Multi station on Christmas	Christmas: ornaments, snowmen, trees.
December 9	9:00AM to Noon	Woodturning Skills Center
December 12	"Note: date is second Tues- day and not third Tuesday."	Holiday party and big show and tell.

In case of inclement weather check the website for  
announcements of possible cancellation.